

WE SENSE DISASTER...  
AND NOW YOU ARE IN CONTROL...

## ropeWaterAcid sensor



The AKCP ropeWaterAcid sensor is a rope type water detector designed for efficient water and battery acid detection monitoring.

The ropeWaterAcid sensor can be connected to any one of the sensorProbe or security-Probe's RJ-45 Intelligent Sensor ports enabling the unit to detect the presence or non-presence of water or battery acid.

This water/battery acid sensor is a switch type that will be on or off and will detect the presence of water or battery acid if any portion of the rope becomes wet.

This sensor comes fully assembled including the Water/Acid sensing rope, the non-sensing cable that connects the rope to the sensing module and the main sensing module that connects via CAT5 LAN cable to the sensorProbe\securityProbe 5E.

The sensing rope cable can be pre-ordered from a 10 foot minimum to any custom run length of up to 165 feet or 50 meters . The non-sensing cable comes in a standard 20 foot run length.

The sensing module is then connected to any of the RJ-45 Intelligent sensor ports on the AKCP base units using standard CAT5/6 LAN cable.

The presence, or non-presence of water/battery acid can be used to trigger alerts like e-mail, SMS, phone calls and SNMP traps. The sensor has its own SNMP OID so that it can be monitored over your network using any Network Management System.

Each ropeWaterAcid sensor comes complete with a 5 foot sensor cable that connects the main sensing module to either the sensorProbe or the securityProbe's RJ-45 sensor ports, or you can use your own CAT5e/6 LAN cable. This cable can be extended up to 100 feet or 30 meters.

## Water

Ideal for use in basements and under false floors and roof spaces, the ropeWaterAcid sensor can cover a large area. Combined with any of the sensorProbe series or securityProbe series units it will give you advance notice of any water leaks or flooding. The sensor will retain its error condition until it is read via an SNMP get. Therefore if the sensor encounters a critical condition at anytime it will report that condition before it returns to a normal state.

## Acid

In power monitoring situations where backup battery and UPS are used to ensure a constant power supply there is a risk of battery's leaking harmful battery acid. Use this rope sensor underneath backup battery banks to give advanced warning of battery acid leaks.

**Note:** *This product is designed for short term exposure to battery acid only. Tested with 40% concentrate Sulphuric acid (H<sub>2</sub>SO<sub>4</sub>)*

## Specifications

- Measurement range: Wet or Dry (-20 degrees C- +60 degrees C)
- Measurement accuracy: able to detect the presence or non-presence of water/battery acid
- The ropeWaterAcid sensor can detect and withstand a 40% concentration of battery acid for short term periods of time without damage to the rope.
- Sensor type: patent pending, microprocessor controlled, capacitance measurement technology
- Power Consumption: Typical 125 mWatt, 25 mA
- Communications cable: RJ-45 jack to main sensor module using UTP CAT5 cable.
- Maximum extension cable run length is 30 meters (100 feet).
- Comes fully assembled including the Water/Acid sensing rope, the non-sensing cable that connects the rope to the sensing module and the main sensing module that connects via CAT5 LAN cable to the sensorProbe\securityProbe 5E.
- Sensing rope cable can be pre-ordered from a 10 foot minimum to any custom run length of up to 165 feet or 50 meters.
- Non-sensing cable comes in a standard 20 foot run length.
- Sensor OID is .1.3.6.1.4.1.3854.1.2.2.1.18.1.3.0

## Features

- Power Source: Powered by the sensorProbe, or securityProbe. No additional power needed. Both units will auto-detect the presence of the ropeWater\Acid sensor.
- Full autosense
- Sensor module LED activates when liquid is detected by the sensor.
- Sensor reports critical status if cable integrity is broken, cut, or unplugged.

## Mounting the ropeWaterAcid sensor

We recommend using any standard plastic U-clip with the adhesive base as shown in these two pictures below. These types of clips can normally be found at your local hardware store.

When installing or handling your new rope sensor, please be sure to handle the rope portion of the sensor with care, avoiding any twisting, excessive bending or putting stress on the rope, as the internal sensing wires are very delicate and can become damaged quite easily.

**UC**  
**U-Clip with Adhesive Base**

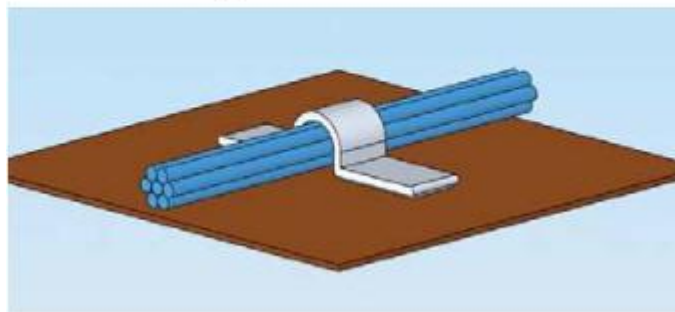

**HUC**  
**Half U-Clip with Adhesive Base**

